



Delivering Performance with the S.KO CITY

IAA Pre-Press Conference – 13th June, 2024

Manoeuvrable, efficient food transport solutions especially for city centres.



Shortest and lowest semi-trailer

New version of the length

- Suitable for cities with low infrastructure (bridges, balconies, trees etc.), with total height of just under 3.68m.
- 2.25m internal height
- Space for 33 roller containers or 22 euro pallets

3.68m



9.14m

Damage prevention and safety are the key benefits of S.KO CITY

No more unpleasant experiences

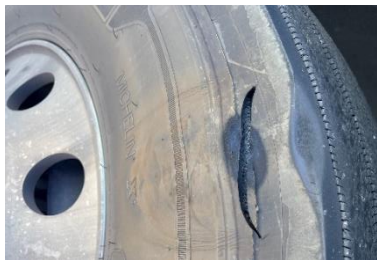

Internal radius “cutting” is prevented thanks to rear steered axle, which can turn up to 28°.

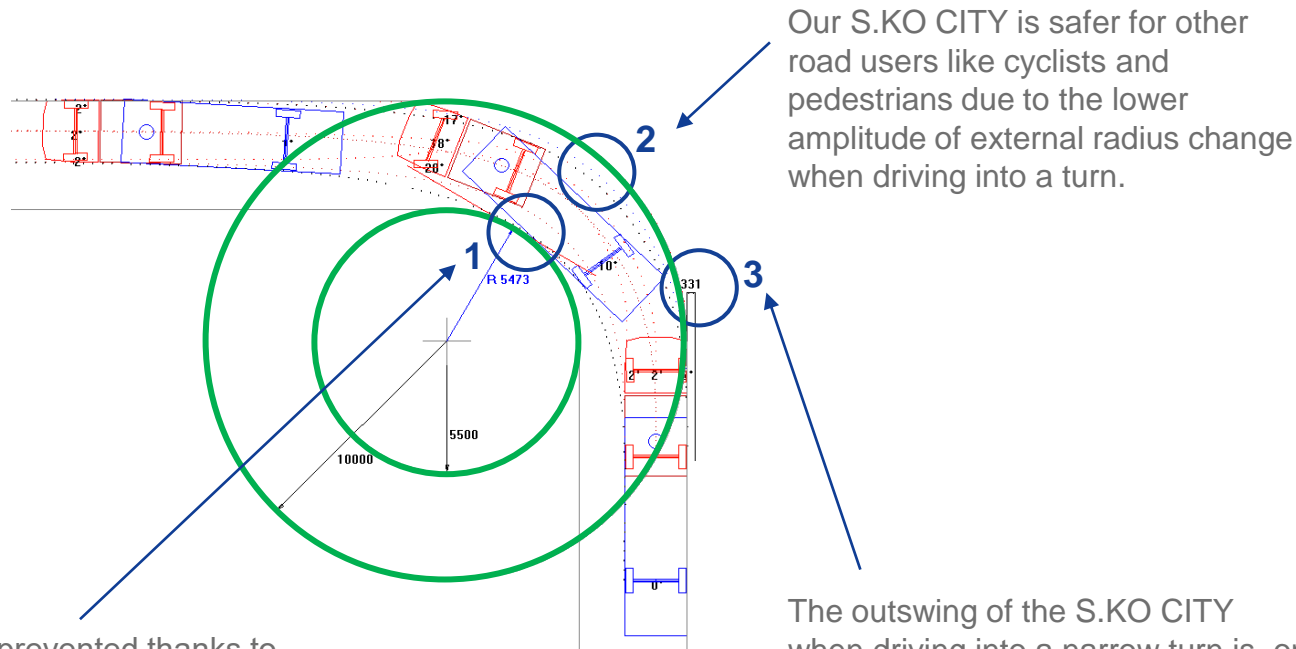

Our S.KO CITY is safer for other road users like cyclists and pedestrians due to the lower amplitude of external radius change when driving into a turn.

The outswing of the S.KO CITY when driving into a narrow turn is, on average, ~20% lower compared to other vehicles.

Twin-tyres

For more safety

- Single axle trailer with twin tyres ensures safety, and reduces the risk of flipping the trailer in case of a tyre blowout



S.KO CITY ensures safe loading without any additional landing gear

Cost and weight savings

- S.KO CITY has a great weight distribution, therefore it does not require additional landing legs in front
- Result of such construction means cost and 100kg weight saving



S.CU d80 - entry-level model for the volume market



Consumption

Low fuel consumption via variable speed control of the diesel engine



Technology

Robust 4 cyl. diesel engine for use in all markets, especially with lower diesel quality



Reliability

- All product updates are included
- Extensive validation
- No external non-return valve



Sustainability

- Less refrigerant
- Hermetised refrigeration circuit



Cooling capacity

Specific cooling capacity for the mid-range transport cooling unit segment



Economy

Lower maintenance costs:

- Oil change interval: 3,000 Bh
- No belt changes
- Elimination of shaft sealing
- Generator is maintenance-free
- Maintenance components are easily accessible



Comfort

Lowest noise volume on the market

- Silence Kit as standard
- Scroll compressor



Networking with TrailerConnect®

- Smart trailer functions integrated
- Incl. 2-way communication



Service

24-month service contract with proactive monitoring of the S.CU d80

Working light package

For more safety

- Slim working lights on the rear frame, for tail lift area lighting
- Environment lights in the area of landing legs, with additional switch
- LED internal lights, activated from tail lift sensor
- Additional reversing lights for extra visibility in the rear
- Top marker lights for more visibility on the road
- Parking lights, with a switch in central electric box

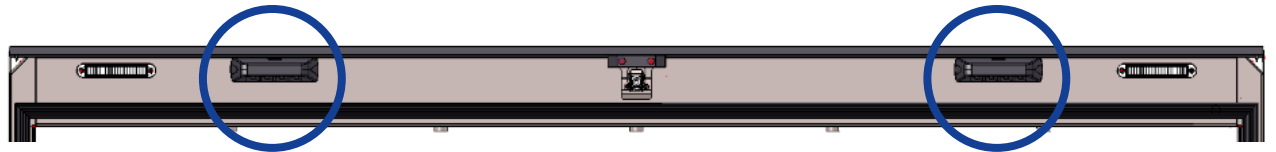

Central electric box

Easier, quicker maintenance

- Updated design – with electric connections inside of the box
- Optimised wiring length
- Circuit diagram for all options inside the central electric box
- Easier, quicker maintenance
- Allows customer to retrofit needed options in a safe and reliable way
- Switch of parking lights inside

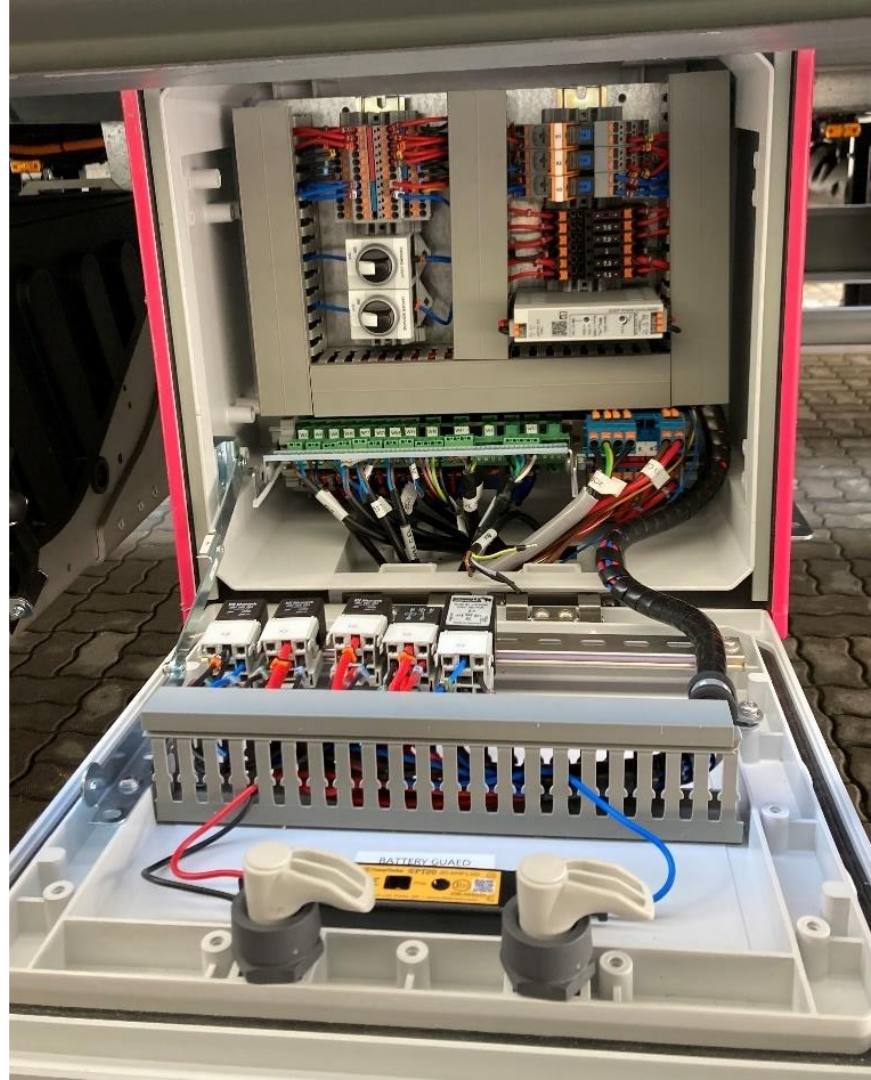

Upgraded battery box

New construction battery box comes with a central switch

- Time saving when service workshop is doing any sort of electrical work, or if the trailer is going to stand for a while, to prevent battery drain

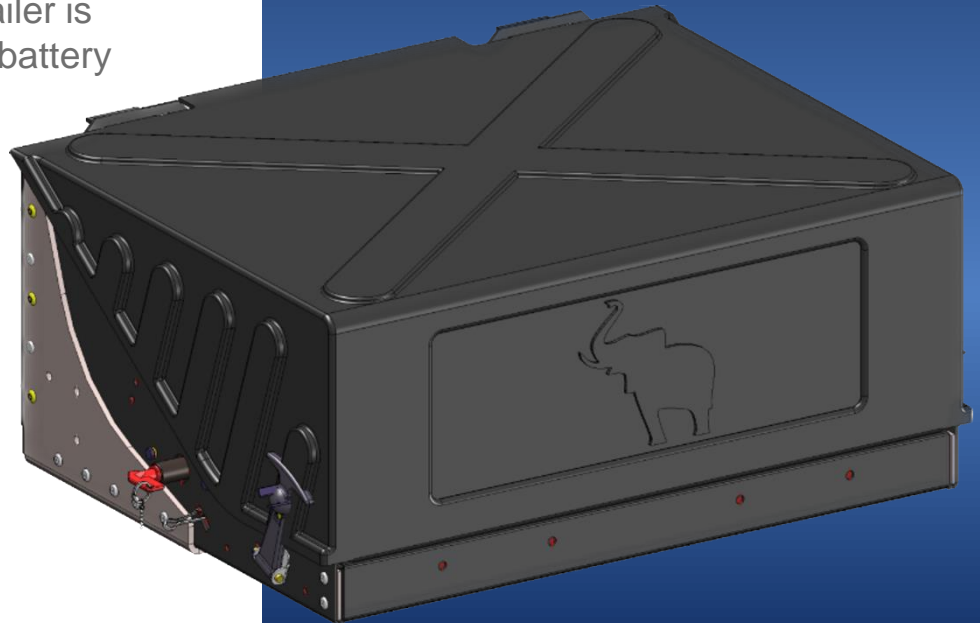

Central lubrication system

For tail lift and steering axle system

- Reduced equipment downtime by ~15%, machine labour costs and replacement rate of components reduced by ~50%
- Central lubrication system is used for tail lift and axle steering system
- Reduces time and costs for supervision of components
- Reduces repair costs
- Adjustable intensity of lubrication, to fit each customer needs



Safety – protection of rear

The system protects the body when the trailer reverses up to a ramp

- DRP 3.0 – Dynamic Ramp Protection a premium Schmitz solution for rear frame protection
- Stainless steel rear light holder with additional protection frame around it
- Reduces any possible damage to a minimum



Safety – Ladder

For increased safety for the driver

- Updated design for safety reasons. The new ladder now has top surface with safer teeth, that are still great for grip, but also reduce the risk of cutting
- Safestart – A safety option, that will apply brakes automatically, if the access ladder is in opened position
- Foldable ladder with a sensor, specially made to be used for safety options like “Safestart” or tail lift platform stopping, if ladder still open

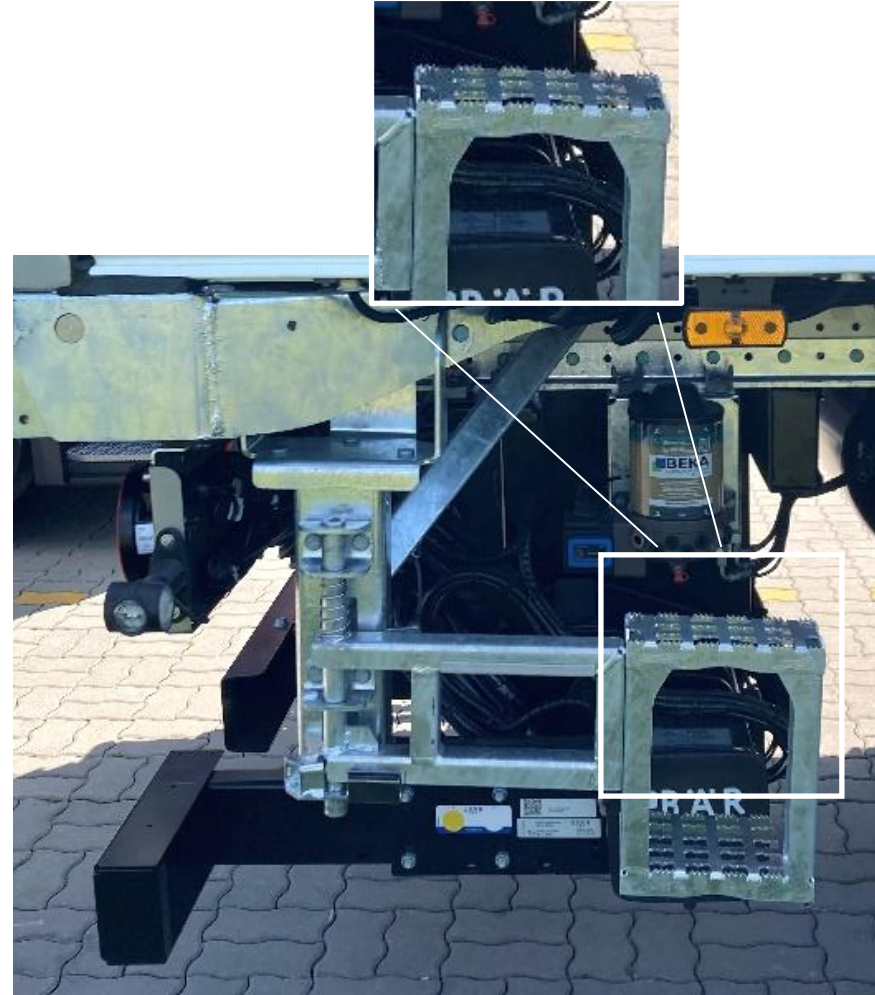

Tail Lift

For greater reliability and lifting efficiency

- 2.5t lifting capacity on a very short overhang
- Better durability, less maintenance required and cheaper repair, compared to lower tonnage tail lifts
- Control of tail lifts recessed under the floor, for additional protection of equipment



Reversing assistants

For greater safety when manoeuvring

- Heavy duty slim camera, with IP69K standard
- White Sound safety system, self adjusting system, ideal for environments with varying levels of noise
- No additional frame protections needed for the camera / working lights, which means no damage for docking ramp curtains

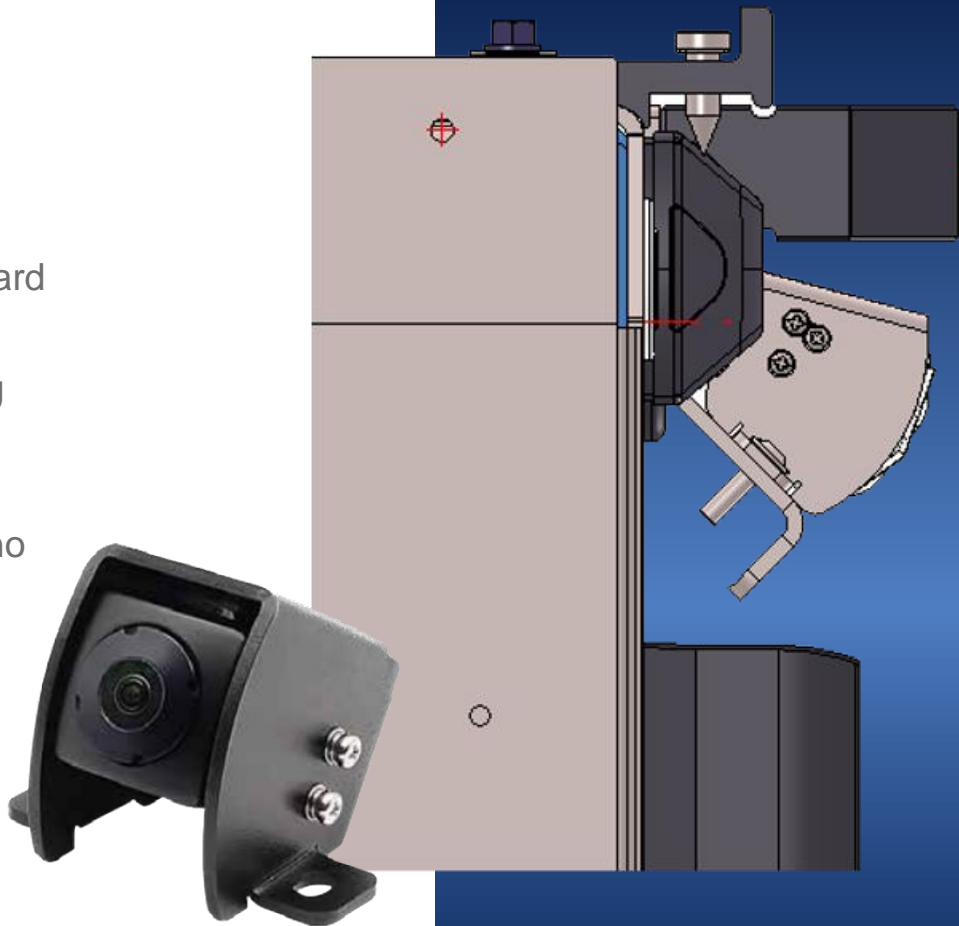

Airline floor

Lip-resistant, easy-to-clean and meets hygiene standards

- Quick, easy and durable load securing solution
- Beams are locked in the holes in floor, and in the holes under the roof
- Additional holes in the rear frame ensure that maximum volume of trailer can be used for goods and the goods won't fall out when opening the tail lift



Driver ergonomic options

For efficient loading

- Airline beam parking position
- Load securing belt (fixing belt) holder, with an updated design and additional stainless-steel protection under the holder
- Foil holder on sidewall, with a pin for locking foil in place
- Short load securing rails in the rear
- Override plate holder in the rear, under the floor, which doesn't require the driver to go around the trailer, or inside the trailer, to use it



Air suspension control from inside

Simple operation for the driver

- Suspension control from inside works without energy supply from the tractor unit (connected to the batteries), which is needed to be suitable for all kinds of loading ramps
- Electronic pneumatic suspension control, with 3 operating buttons – UP, DOWN, WAKEUP



3-part insulated curtains

Reduction of unwanted air circulation

- Insulated curtains with magnetic sides, for better sealing
- Easy one-hand control
- Quick closing of temperature-controlled loading space, for minimum energy losses when loading / unloading

