



The S.CF DOCK 20/40 container chassis

Efficient and safe transport of 20' and 40' containers

The optimum solution for economical transport and rear-flush transport of 20' and 40' containers. The factory-fitted TrailerConnect® telematics and the tyre pressure monitoring system (TPMS) with autolocation ensure greater safety and create maximum transparency in your fleet.

Why is the S.CF DOCK the best solution for you?

The semi-trailer container chassis is robust and extremely durable with a galvanised chassis. Thanks to the intuitive operating concept and simple user guidance, containers can be changed quickly and safely.



Maximum efficiency and safety

The S.CF DOCK carries 20' containers flush with the rear, as well as 2 x 20' containers and 40' containers. The new robust underride guard at the rear and optimised spare parts supply through the use of Schmitz Cargobull standard elements provide additional safety.



Simple handling meets intuitive operating concept

The pneumatic rear extension is easy and time-saving to operate. The simplified user guidance impresses with clear instructions on the vehicle and operating videos via QR code.



The TrailerConnect® tyre pressure monitoring system with autolocation is included ex works

The correct tyre pressure reduces rolling resistance, fuel consumption and tyre wear. All container chassis are equipped with TrailerConnect® telematics and tyre pressure sensors as standard.

Simple, safe,
economical.

Quality is the top priority for all components.
Our goal is maximum durability, which we
achieve through the galvanised chassis and
precise workmanship.



TWIST LOCKS with anti-twist lock on four pairs of container beams as standard.





With 2 x 20' loads, the height-adjustable **KLAPP LOCK** takes over the locking of the front container.

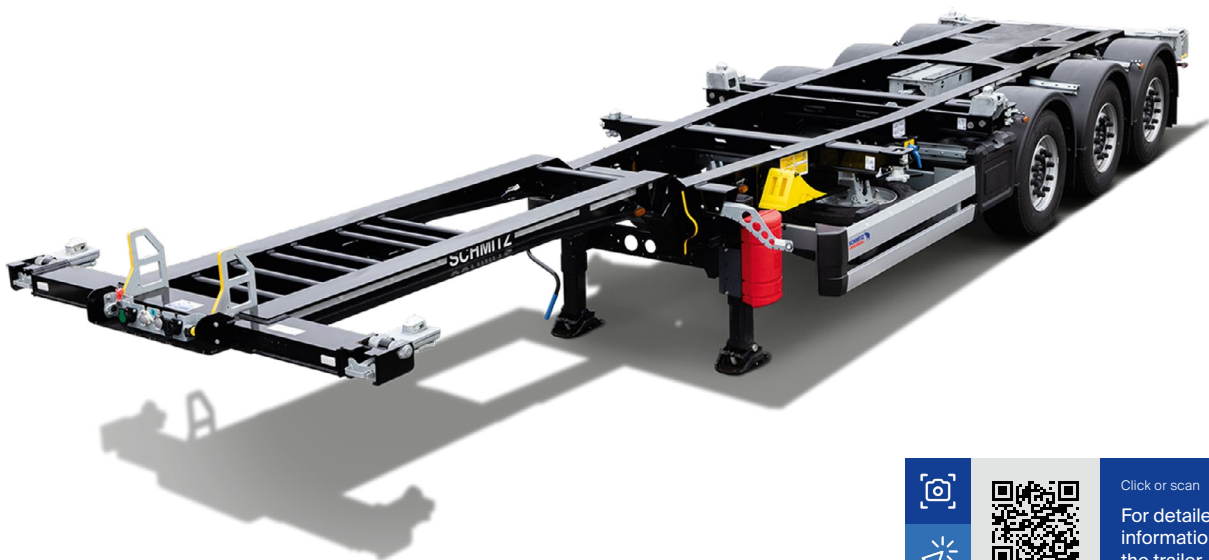

Easily replaceable **container guides** on the front beam.



Click or scan
For detailed
information on
the trailer



New operating concept with loading plan and clear function and warning notices on locks and extensions.



Control for the pneumatic rear extension, optionally with manual locking.



For more safety: **New damped rear extension moves pneumatically** to the selected locking position and brakes gently.

Intermodal transport - reliable and innovative.

As a strong partner for your success, we provide you with transport solutions and services you can rely on, for greater economy, efficiency and transparency in your fleet and along the supply chain.

TrailerConnect® telematics

In every S.CF DOCK 20/40 ex works

For efficient fleet management, intelligent scheduling and the reduction of your process costs. Including access to the telematics portal and the beSmart and beUpToDate apps.

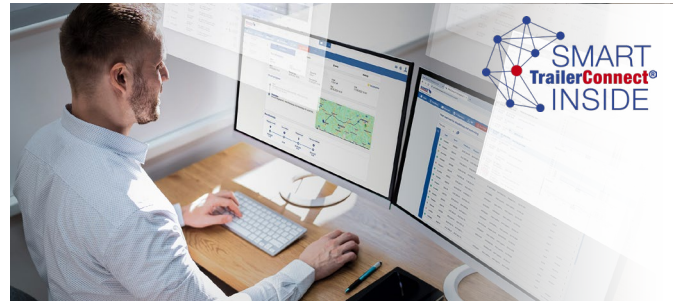

Service contracts

Customised for your container chassis

With the right service contract, you retain full control over costs and we ensure that you always remain mobile, so you can concentrate fully on your business.



You can rely on:

The Schmitz Cargobull premium services and the competent partner network.

- Customised financing and insurance from industry professionals
- TrailerConnect® Telematics and Digital Services for Smart Logistics
- Second Hand – First Class Used in tested quality
- Spare parts that pay off, for the time value fair repair
- Full Service for trailer, cooling unit and tyres
- Order Genuine Spare Parts online, delivery within 24h
- 1,400 Service Partners - your specialist workshop network
- 24h Cargobull Euroservice assistance across Europe

Click or scan
Find out more about our exclusive services here.

Do you have any further questions for us?
We are happy to advise you!

T +49 (2558) 81-0
www.cargobull.com